

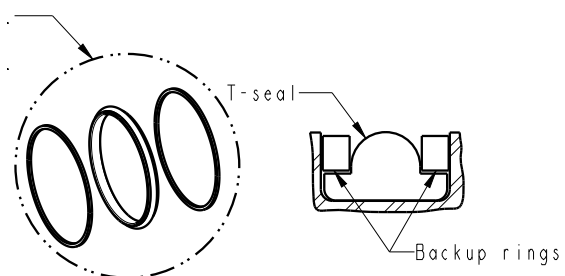

Lubricate all seals with clean hydraulic fluid, prior to assembly. Do not use silicone type lubricants.

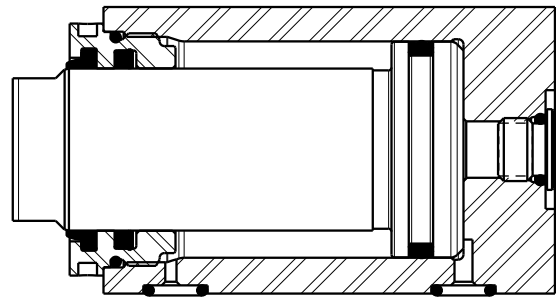
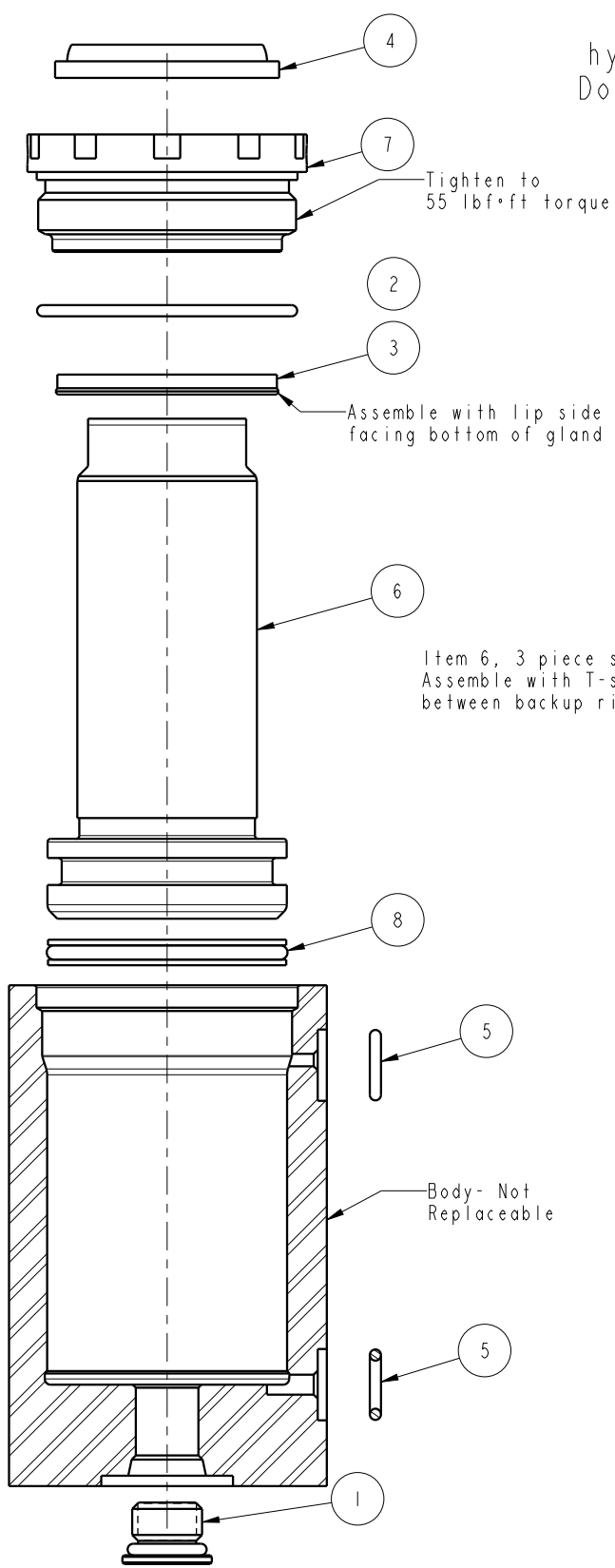

Standard Seal Kit	Fluorocarbon Seal Kit
60-2102-01	6V-2102-01
39-H110-31	39-V110-31
39-0110-48	39-0120-07
39-0010-13	39-0120-14
39-0500-20	39-0500-20
39-0500-42(2)	39-0510-25(2)

No.	QTY	PART No.	DESCRIPTION
8	1	39H11031	SEAL, T, (1 5/16X5/32X1 1/2)
7	1	82031501	GLAND, CYL, 8800 & 39.9 KN
6	1	82011507	PISTON, CYL, 8800, 1.5 STRK
5	2	39050042	O-RING, (-011)
4	1	39050020	WIPER, SNAP-IN, (1-1/8)
3	1	39011048	SEAL, LL, (1-1/8 X 1/8 X 1/8 X 1-3/8)
2	1	39001013	O-RING, (-029)
1	1	30601145	PLUG, SOCH, SAE 4, LOW HEAD

<b>PARTS LIST</b>	 VEKTEK, INC. 1334 E. SIXTH AVE. P.O. BOX 625 EMPORIA, KS. 66801 U.S.A.	
	Model Number <b>21-1215-04</b> <b>21-1215-04F</b>	
ASSY, CYL, BB, MM, 8800, 1.5 STRK, DA		SIZE <b>A</b>
<b>PL2166</b>		REV <b>F</b>

F	5499	RELEASE	NPETERS	9/23/24
REV	IN ACCORDANCE WITH ECN	EFFECTIVE DATE	REVISED BY	DATE
DRW BY:	JACOB	<b>DRAWING STATUS: Released</b> PRODUCTION APPROVED FOR RELEASED STATUS ONLY		
DATE:	5-8-97			